

Optical Fiber Tester

USER'S MANUAL

Warning

When using this instrument, please do not look directly at the optical interface or the end of the optical fiber with your eyes, avoid eye damage! Except for 1625nm/1650nm, all the others are non-on-line test wavelength, it will cause damage to the internal devices of the instrument if it is used forcibly! Any change or modification not explicitly permitted in this manual will deprive you of the right to operate the equipment. To reduce the risk of fire or electric shock, do not expose the equipment to thunderstorm or humid environment. In order to prevent electric shock, do not open the shell, it must be repaired by the qualified personnel designated by the manufacturer.

Attention

Battery: The battery in the machine is a special lithium-ion polymer battery. The charging voltage is 5V, and the charging temperature ranges from 0°C~50°C. When the ambient temperature is too high, the charging will automatically terminate. The instrument battery should be charged every one month to avoid battery failure due to self-discharge after long time storage. The temperature range of the battery during long-term storage is -20°C~45°C. Please use the special AC adapter attached to this instrument and use the external power supply strictly according to the specifications, otherwise the equipment may be damaged.

Fiber End Face Cleaning: Before testing, clean the end face of the tested optical fiber joint with alcohol cotton.

LCD screen: The display of this series of instruments is 3.5 inch color LCD. In order to maintain good viewing effect, please keep the LCD screen clean and clean. When cleaning, the LCD screen can be cleaned by wiping with soft fabric.

Guarantee description: The whole machine is guaranteed for 36 months. The battery, charging adapter and optical interface consumables are guaranteed for 6 months. The warranty date shall be postponed one month from the date of manufacture.

Due to the need of design improvement, the contents are subject to change without notice.

Brief

1.

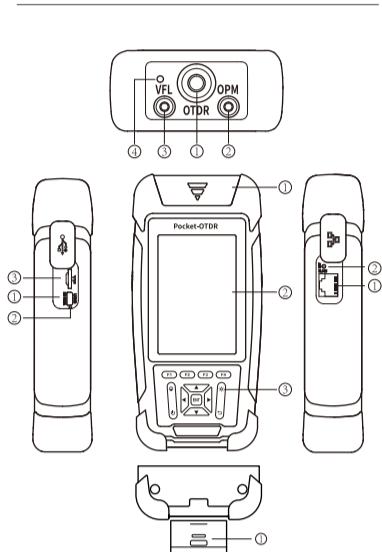

Top view

- ① OTDR/LS Port
- ② OPM Port
- ③ VFL Port
- ④ Flashlight

Right side

- ① RJ45 Interface
- ② Reset button

Main view

- ① Dust Cover
- ② 3.5 inch Color LCD
- ③ Function Keys

Left side

- ① Micro USB
- ② Charging LED Indicator
- ③ TF Card Port

Bottom view

- ① RJ45 Remote tester

Functional Keys

2.

Functional keys
Correspond to the operation menu below the screen.



Zoom key

Zoom function key, combined with direction keys to operate.

ON/OFF key

Short press to turn on, long press to turn off; after turning on, long press to turn on or off the flashlight.

ENT key

Enter the next level of interface, Enter function

Measure key

Press to start or stop the test under the OTDR interface

Exit key

Return to the previous menu

Directional keys

Up and down choice, right and left choice

Main Interface

3.

Turn on and enter the main menu. There are eight functional modules. Select the module by pressing the direction keys, and then press the ENT key to enter the corresponding functional interface.

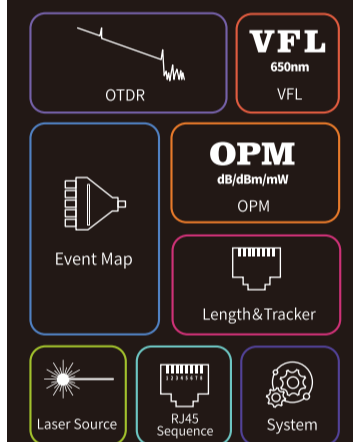
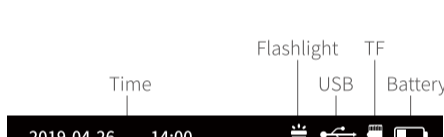

OTDR

4.

F1: Enter the parameter setting interface
F2: Switching A/B cursor
F3: Enter the save interface
F4: File or Folder operation

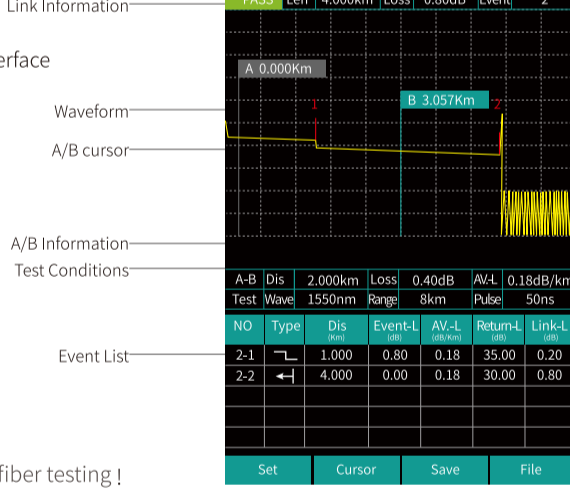

Attention

This function pls don't make live fiber testing!

OTDR Setting Interface

5.

OTDR setting interface

Enter the parameter setting interface. Multi-digit settings, through the left and right key positioning cursor, up and down selection.

▲▼: Choosing settings items.

Press ENT button to confirm or edit corresponding measurement parameters.

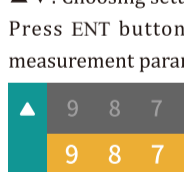

F1: Test

F2: OK

F3: Recovery

F4: Cancel

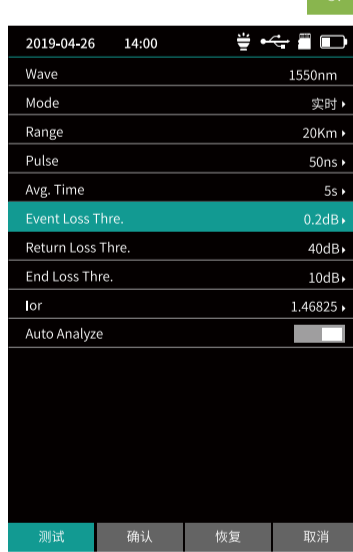

Test Results

6.

Link quality and information can be viewed from the top after the test is completed,

Link information includes length, total loss and number of events,

Detailed event information can be viewed from the event list.

There are Four types of events:

Reflective event

Non-reflective event

Fiber splitter

Fiber end

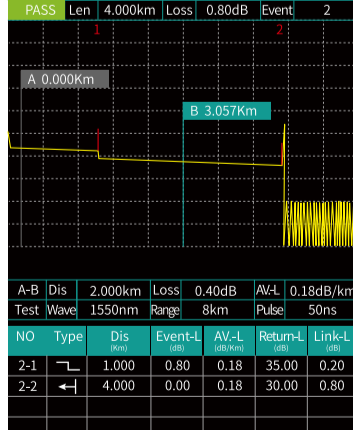

OTDR-Zoom mode

7.

Press to enter zoom mode

X-axis direction zoom in

X-axis direction zoom out

Y-axis direction zoom in

Y-axis direction zoom out

Press 1:1 display

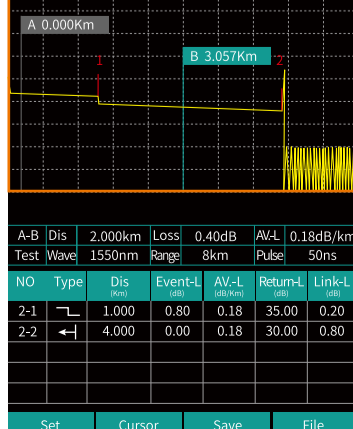

OTDR-File Save

Press **F3** (Save) key to save file after test complete, pop up the keyboard, enter the name of the file, and press Enter to save the file. If the automatic save (otdr) function is turned on in "System Settings", it will be saved automatically after the test complete without manual operation.

Auto-save function

Enter the system settings, open the auto-saving function, the instrument will automatically save the test files after the average or auto-test.

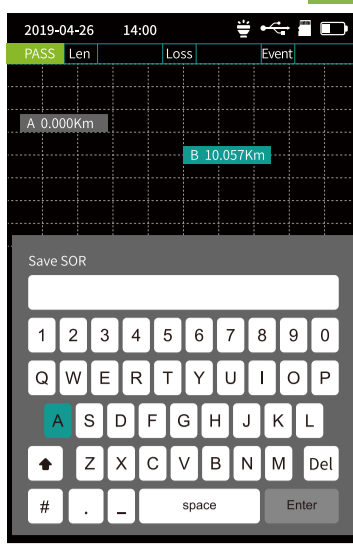

OTDR-File Operation

OTDR-File Operation

Press **F4** to enter the file list.
Press the **ENT** key to open a folder or File.

- F1: Open file
- F2: Delete file
- F3: Rename file
- F4: Return to the main menu

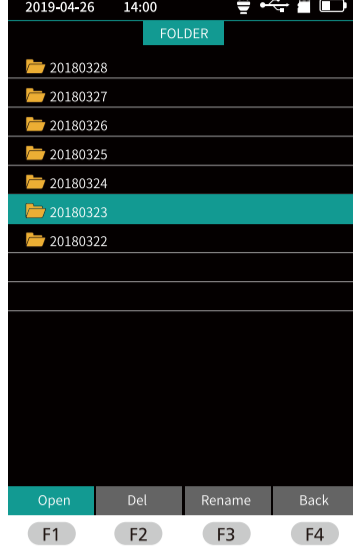

iLOM(Event Map)

The function can be tested automatically by one key, and the information of the length of the link, the type of event point and the position of breakpoint can be displayed in a graphical form. The result is clear and easy to understand.

Left/Right key: Switching events.

- The starting point of the link, after the guiding fiber is added to the front
- Drop event, representing fusion point
- Rising event, caused by the inconsistency of refractive index of two sections of fiber
- Connector, square flange, SC, LC etc
- Optical fiber macro bending
- Optical fiber splitter
- End of link

Attention This function pls don't make live fiber testing!



OPM

This function is used to test the power of optical signal and insertion loss of various devices and optoelectronic components. It can identify and measure the frequency of 270/330/1k/2kHz frequency optical signal.

- F1: Switching wavelength
- F2: Setting Reference Power
- F3: Zero Reference Power
- F4: Enter the Calibration Mode

Absolute power, relative power and linear power are converted as follows:

$$P_{Abs.} = 10 \lg P_{Lin.} / 1mW$$

$$P_{Rel.} = P_{Abs.} - P_{Ref.}$$

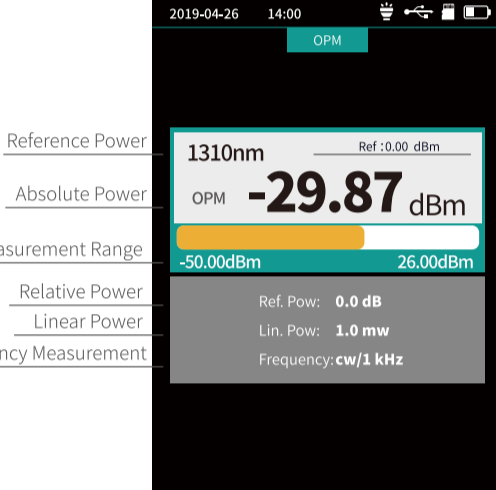

VFL

Visible red light (650 nm) is injected into the optical fiber, and the position of the optical fiber fault point can be judged conveniently and accurately by observing the leakage position on the measured fiber. It is suitable for the detection of bare optical fibers, jumpers and other high loss sections caused by near-end faults and micro-bending of optical fibers and cables which can leak red light.

Avoid looking directly at the laser output port. Laser can cause damage to human retina.

- F1: Open VFL
- F2: VFL flash at 1 Hz
- F3: VFL flash at 2 Hz
- F4: Turn off VFL

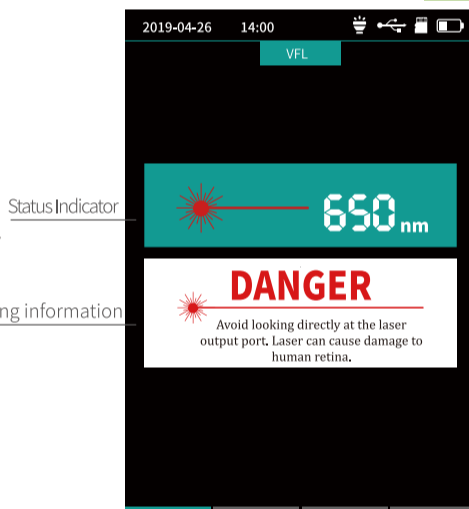

LS-Laser Source

The wavelength of stabilized laser source is the same as OTDR wavelength. It is used to measure the parameters of telecommunication, CATV, LAN cable, insertion loss, isolation loss and echo loss of optical passive devices, and wavelength responsiveness of detectors.

There are five modes of light source: CW, 270 Hz, 330 Hz, 1 kHz and 2 kHz.

- F1: Open LS
- F2: Turn off LS
- F3: Switch LS Wavelength
- F4: Switch LS Mode

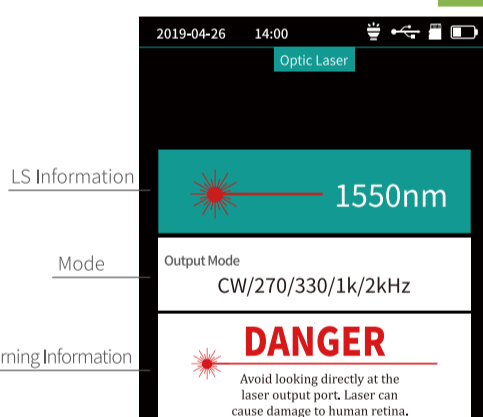

RJ45 Sequence

RJ45 line sequence measurement.

- F1: Start Test
- F3: Switch Line Sequence Test Standard
- F4: Return to the main menu

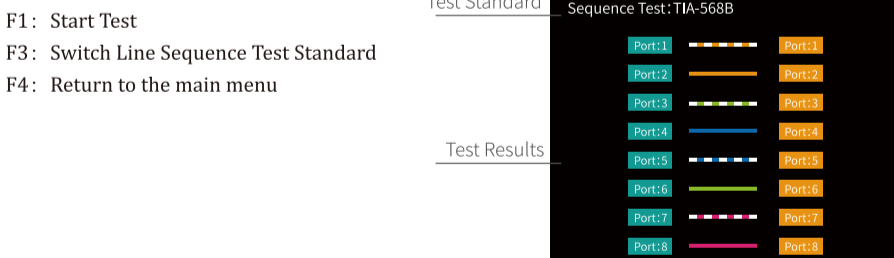

Attention Pls cut off the electricity before test!

Tips: Please connect the remote device. Click F1 for cable sequence test.

RJ45 Line Length & LineTracker

RJ45 Line Tracker

Used for RJ45 cable length testing and wire tracker. After the line-finding function is activated, the cable being searched is touched by the distal end of the line-searching, and the sound of continuous "drops and drops" is heard.

The Line-Tracker test is under way. Please use the remote line-finding module to test and click the return key to exit.

- F1: Start Line Length Test
- F2: Switch Line Length Unit
- F3: Switch Line Sequence Test Standard
- F4: Start Line-tracker Function



Attention Pls cut off the electricity before test!

Tips: Click F1 for cable length test. Click F4 for cable track test.

System settings

Set up automatic shutdown, backlight brightness, time, language, upgrade and other information.

- F1: Optional for switching the current menu
- F3: System Software Upgrade
- F4: Confirmation settings



Switch settings entry ▲▼
Switch options of current entry ►◀

